

STEP 1

INSERT "J" LEG PANEL THEN INSERT LEG INTO "J" LEG

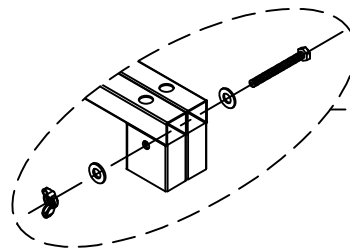

OPTION WITH MORE THAN ONE WORKSTATION

BOLT EACH LEG & ROD WITH
1/4"-20x2-1/2"L HEX BOLT
1/4"φ WASHER
1/4"-20 WING NUT

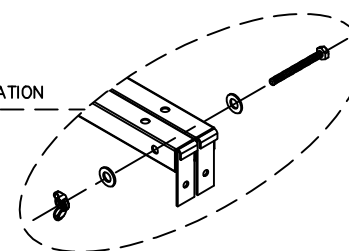

BOLT EACH LEG & ROD WITH
1/4"-20x2-1/2"L HEX BOLT
1/4"φ WASHER
1/4"-20 WING NUT

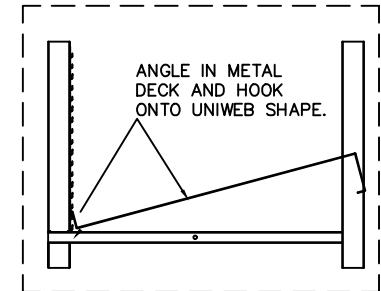

ANGLE IN METAL DECK AND HOOK ONTO UNIWEB SHAPE.

STEP 4

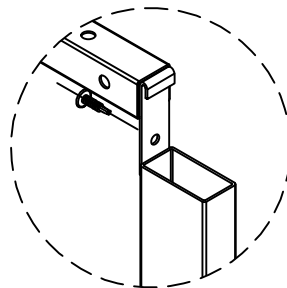

STEP 2

SLIDE COUNTER ROD INTO "J" LEG AND PANEL FOR MORE STABILITY SCREW EACH ROD WITH #10x3/4"L MOD TRUSS (SELF DRILLING SCREW)

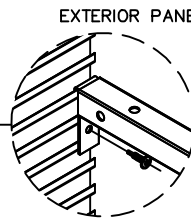

EXTERIOR PANEL (1)

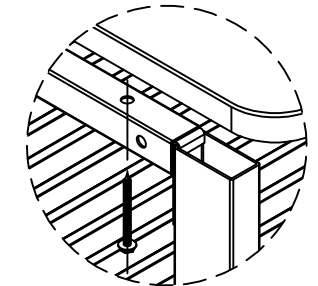

STEP 5

SCREW THROUGH COUNTER TOP ROD AND INTO COUNTER TOP

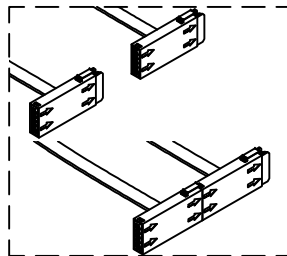

STEP 3

CONNECT ALL ELECTRICAL BY DASIY CHAINS THEM TOGETHER (MAKE TO FOLLOW FLOW ARROWS)

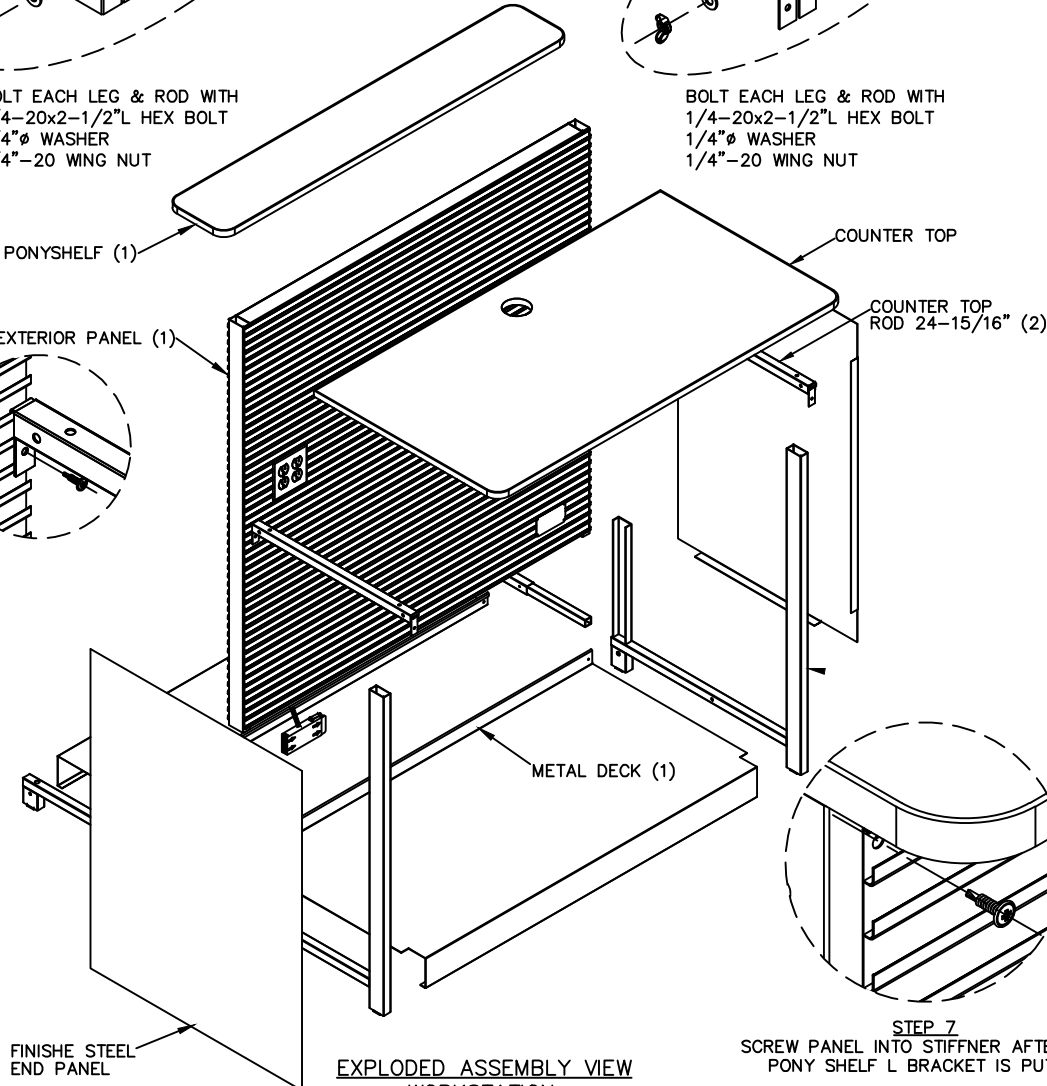

EXPLODED ASSEMBLY VIEW WORKSTATION

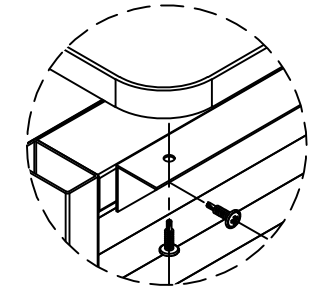

STEP 6

SCREW L BRACKET TO STIFFNER AND PONY SHELF (MAKE SURE PONY SHELF IS STRAIGHT AND LEVEL)

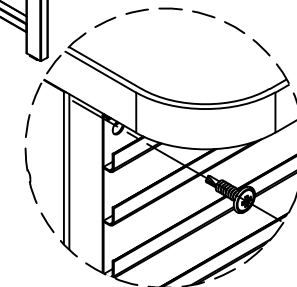

STEP 7

SCREW PANEL INTO STIFFNER AFTER THE PONY SHELF L BRACKET IS PUT IN

UNIWEB INC.
We Create Space

222 So. Promenade Ave. Corona Ca, 92879 (951) 279-7999 1-800-4-UNIWEB UNIWEBINC.COM

DESIGNED BY: AV	SALESMAN:	APPROVED BY:	REF. NO:	DATE: 9-25-17	SCALE: N.T.S.
--------------------	-----------	--------------	----------	------------------	------------------

48" Workstation

REV: **1 OF 1**